

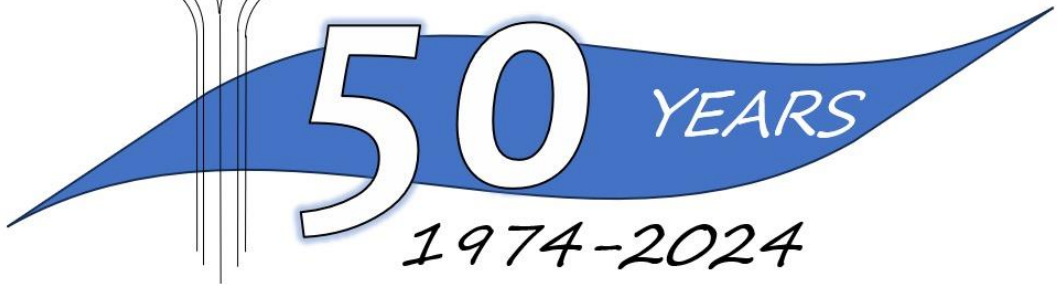

# Community of Christ Lutheran Church



*Community of Christ Lutheran Church  
Sixth Sunday of Easter, May 5, 2024, 9:00 a.m.  
Pastor Stephen C. Bond*

## THE GATHERING

Musical Prelude

Academy Brass Quintet

Welcome

Pastor Steve Bond

**P Christ is Risen! He is Risen Indeed!**

## WE REMEMBER OUR BAPTISM

*All may make the sign of the cross, the sign marked at baptism, as the presiding minister begins.*

Blessed be the holy Trinity, ✝ one God, the wellspring of grace, our Life, and our Joy. **Amen.**

Look, here is water!

**Here is our water of life! Alleluia!**

Immersed in the promises of baptism, let us give thanks for what God has done for us. We give you thanks, O God, for in the beginning your voice thundered over the deep, and water became the essence of life. Adam and Eve beheld Eden's verdant rivers. The ark carried your creation through the flood into a new day. Miriam led the dancing as your people passed through the sea into freedom's land. In a desert pool, the Ethiopian official entered your boundless baptismal life. Look, here is water! **Here is our water of life! Alleluia!**

At the river, your beloved Son was baptized by John and anointed with the Holy Spirit. By the baptism of Jesus' death and resurrection, you opened the floodgates of your reconciling love, freeing us to live as Easter people. We rejoice with glad hearts, giving all honor and praise to you, through the risen Christ, our source of living water, in the unity of the Holy Spirit, now and forever. **Amen.**

Look, here is water!

**Here is our water of life! Alleluia!**

### Hymn

“O God Of All Our Stories”



- 1 O God of all our sto - ries, who formed us from the earth,
- 2 Re - mem - ber - ing the pla - ces you led us on the way
- 3 With mem - o - ries and mile-stones, with vis-ions yet to be,
- 4 Here gath-ered at your ta - ble and fed with brok-en bread,



we mar-vel at this peo - ple that you have brought to birth.  
we bring our grate-ful prais - es in thanks to you this day.  
we find be - long - ing here in be - loved comm - u - ni - ty.  
you make of us Christ's bod - y, a - ris - en from the dead,



Your pres-ence and your prom-ise have made this ho - ly ground  
For call-oused hands that la - bored, for laugh-ter and for tears,  
You claimed us at the wa - ter, you made us each your own,  
to share with all your good - ness, to lav - ish grace un - priced,



from all our var - ied jour - neys, we find that we've been found.  
for walk - ing close be - side us, to hope be - yond our fears.  
now fill us with your gos - pel for ma - king Je - sus known.  
to be who you have called us: comm - u - ni - ty of Christ.

### Greeting

**P** The grace of our Lord Jesus Christ, the love of God, and the communion of the Holy Spirit be with you all. **C** **And also with you.**



Now the feast and cel - e - bra - tion, all of cre - a - tion



sings for joy to the God of life and love and free - dom;



praise and glo - ry for - ev - er - more!



1 Now is the feast of the Lamb once slain, whose blood has

freed and u - nit-ed us to be one great peo-ple of God.

2 Pow - er and rich-es, wis-dom and might, all hon - or and

glo - ry to Christ for - ev - er.

3 For God has come to dwell with us, to make us peo-ple of

God; to make all things new.

### Prayer of the Day

P O God, you have prepared for those who love you joys beyond understanding. Pour into our hearts such love for you that, loving you above all things, we may obtain your promises, which exceed all we can desire; through Jesus Christ, your Son and our Lord, who lives and reigns with you and the Holy Spirit, one God, now and forever. **Amen.**

### Childrens Sermon

**Anthem**

“Heaven’s Gonna Be My Home”

**Choir and ABQ**

## THE READINGS

### **The First Reading: Acts 10:44-48**

*Marsha Cochran*

<sup>44</sup>While Peter was still speaking, the Holy Spirit fell upon all who heard the word. <sup>45</sup>The circumcised believers who had come with Peter were astounded that the gift of the Holy Spirit had been poured out even on the Gentiles, <sup>46</sup>for they heard them speaking in tongues and extolling God. Then Peter said, <sup>47</sup>“Can anyone withhold the water for baptizing these people who have received the Holy Spirit just as we have?” <sup>48</sup>So he ordered them to be baptized in the name of Jesus Christ. Then they invited him to stay for several days.

**L The Word of the Lord C Thanks be to God!**

### **The Second Reading: 1 John: 5:1-6**

*Nancy Ferne*

<sup>1</sup>Everyone who believes that Jesus is the Christ has been born of God, and everyone who loves the parent loves the child. <sup>2</sup>By this we know that we love the children of God, when we love God and obey his commandments. <sup>3</sup>For the love of God is this, that we obey his commandments. And his commandments are not burdensome, <sup>4</sup>for whatever is born of God conquers the world. And this is the victory that conquers the world, our faith. <sup>5</sup>Who is it that conquers the world but the one who believes that Jesus is the Son of God?

<sup>6</sup>This is the one who came by water and blood, Jesus Christ, not with the water only but with the water and the blood. And the Spirit is the one that testifies, for the Spirit is the truth.

**L The Word of the Lord C Thanks be to God!**

*Congregation:*

Al-le-lu - ia, al-le-lu - ia. Lord, to whom shall we  
go? You have the words of e - ter - nal  
life. Al - le - lu - ia!

*Optional Repeat*

## **The Holy Gospel: John 15:9-17**

*Bishop Daniel Beaudoin*

**P** The Holy Gospel according... **C Glory to you, O Lord!**

[Jesus said:] <sup>9</sup>“As the Father has loved me, so I have loved you; abide in my love.

<sup>10</sup>If you keep my commandments, you will abide in my love, just as I have kept my Father’s commandments and abide in his love. <sup>11</sup>I have said these things to you so that my joy may be in you, and that your joy may be complete.

<sup>12</sup>“This is my commandment, that you love one another as I have loved you. <sup>13</sup>No one has greater love than this, to lay down one’s life for one’s friends. <sup>14</sup>You are my friends if you do what I command you. <sup>15</sup>I do not call you servants any longer, because the servant does not know what the master is doing; but I have called you friends, because I have made known to you everything that I have heard from my Father. <sup>16</sup>You did not choose me but I chose you. And I appointed you to go and bear fruit, fruit that will last, so that the Father will give you whatever you ask him in my name. <sup>17</sup>I am giving you these commands so that you may love one another.”

**P** The Gospel of the Lord! **C Praise to you, O Christ!**

**Sermon**

*Bishop Daniel Beaudoin*

**Hymn**

“Love Divine, All Loves Excelling”

**ELW 631**

### **Recognition of Charter Members and Rite of Conferring Pastor Emeritus Status for Pastor Ray Gottschling**

*(In addition to recognizing those founding members of Community of Christ who are present today in worship, we also want to honor our founding pastor, Rev. Ray Gottschling, with the status of "Pastor Emeritus," a designation recognizing Pastor Ray's longtime service to this congregation and the wider church, and honoring him for his dedication to the people of God.)*

**Nicene Creed**

**C We believe in one God, the Father, the Almighty, maker of heaven and earth, of all that is, seen and unseen.**

**We believe in one Lord, Jesus Christ, the only Son of God, eternally begotten of the Father, God from God, Light from Light, true God from true God, begotten, not made, of one Being with the Father. Through him, all things were made. For us and for our salvation, he came down from heaven; was incarnate of the Holy Spirit and the virgin Mary, and became truly human. For our sake he was crucified under Pontius Pilate; he suffered death and was**

**buried. On the third day, he rose again in accordance with the scriptures; he ascended into heaven and is seated at the right hand of the Father. He will come again in glory to judge the living and the dead, and his kingdom will have no end.**

**We believe in the Holy Spirit, the Lord, the giver of life, who proceeds from the Father and the Son, who with the Father and the Son is worshiped and glorified, who has spoken through the prophets. We believe in one holy catholic and apostolic church. We acknowledge one baptism for the forgiveness of sins. We look for the resurrection of the dead, and the life of the world to come. Amen**

### **WE DEDICATE OUR HEARTS IN PRAYER**

**P** Rejoicing that Jesus is risen, and love has triumphed over fear, let us pray for the church, the world, and all those in need of good news.

*A brief silence.*

**AM** Your Holy Spirit falls upon all who hear the word. Fill your church with the gifts of your Spirit and give understanding hearts to those who strengthen our commitments with our ecumenical and interreligious partners. God of grace, **hear our prayer.**

**AM** You speak and the face of the earth is renewed. Revive your creation, that habitats and every kind of living thing might flourish. Protect endangered species and help us to care for all your creatures. God of grace, **hear our prayer.**

**AM** Your world is divided and the nations rage. Grant wisdom and vision to world leaders, that they may seek justice, peace, and the good of all. Strengthen international partnerships and cooperation. God of grace, **hear our prayer.**

**AM** Your children are in need. Comfort all those who suffer, especially those afflicted by anxiety, depression, and mental illness. Help us to be conduits of your love in our care for one another; **Tom Jennings, Sue & Jim Enk, Christal & Chad Pritchard, Frank O’Konski, Kim Mockensturm, Larry Geer, Troy Bernhard, Kevin Stiles, Susie Donnal, Harold Shoup Jr, Bernie Mank, Cory Kaczor...** and all others whom we remember in silence. God of grace, **hear our prayer.**

**AM** Your work is done in this place with our hands. Bless the ministries of this congregation, that we may embody your love for the world. Inspire those who plan and lead worship, council members, committee members, and volunteers. God of grace, **hear our prayer.**

**AM** Your blessed saints now rest in you. Give us thankful hearts for those who have gone before us. At the last, bring us all together around your heavenly banquet table. God of grace, **hear our prayer.**

**P** Into your hands, most merciful God, we commend all for whom we pray, trusting in your abiding love; through Jesus Christ, our resurrected and living Lord. **Amen.**

### **THE MEAL**

*All Christians are welcome to commune at our Altar. You do not have to be a member of this congregation to receive Communion. Grape juice is available in the inner ring of glasses for those desiring it. A "gluten-free" host option is available upon request as well.*

### **Sharing of the Peace**

**P** The Peace of the Lord be with you all! **C And also with you!**  
*Share an expression of peace with your neighbor, please.*

**Our Tithes and Offerings** *"Our Tithes and Offerings: The congregation is seated as the ushers pass our offering plates to give our offerings to God's service, and then the ushers will bring the offering plates forward."*

### **Offertory Hymn**

**ABQ**

### **Offering Prayer**

**AM** Risen One, you call us to believe and bear fruit. May the gifts that we offer here be signs of your abiding love. Form us to be your witnesses in the world, through Jesus Christ, our true vine. **Amen.**



# THE GREAT THANKSGIVING

*Presider:* The Lord be with you. *Congregation:* And al - so with

*Presider:* you. *Congregation:* Lift up your hearts. We

*Presider:* lift them to the Lord. *Congregation:* Let us give

*Congregation:* thanks to the Lord our God. It is

right to give God thanks and praise.

**\*\*The Eucharistic Prayer Continues.....**

## HOLY

*Congregation:* Ho - ly, ho - ly, ho - ly are you, God of pow - er and

might; Heav - en and earth are filled with your

glo - ry. Ho - san - na in the high - est!

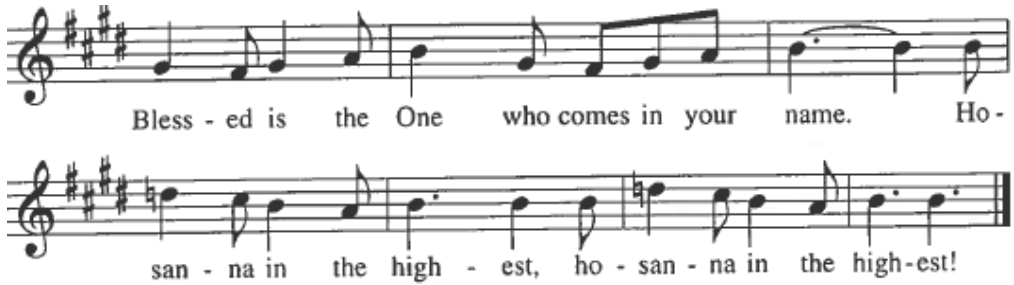

### The Words of Institution

*In the night in which he was betrayed, our Lord Jesus took bread, and gave thanks; broke it, and gave it to his disciples, saying: Take and eat; this is my body, given for you. Jesus said, Do this for the remembrance of me. Again, after supper, he took the cup, gave thanks, and gave it for all to drink, saying: This cup is the new covenant in my blood, shed for you and for all people for the forgiveness of sin. Jesus said, Do this for the remembrance of me.*

### The Lord's Prayer

**P** Lord, remember us in your kingdom and teach us to pray... **C** Our Father, who art in heaven, hallowed be thy name, thy kingdom come, thy will be done, on earth as it is in heaven. Give us this day our daily bread, and forgive us our trespasses, as we forgive those who trespass against us; and lead us not into temptation but deliver us from evil. For thine is the kingdom, and the power, and the glory, forever and ever. Amen.

*This morning at Communion, we will have a total of four stations to receive: three in the front, and the fourth at the back near the baptismal font. Please follow the invitation of the ushers to come forward to the station to which they direct you, and follow back along the next aisle back to your place. Those needing a gluten-free host may go to the station at the center where Bishop Beaudoin will have gluten-free hosts available.*

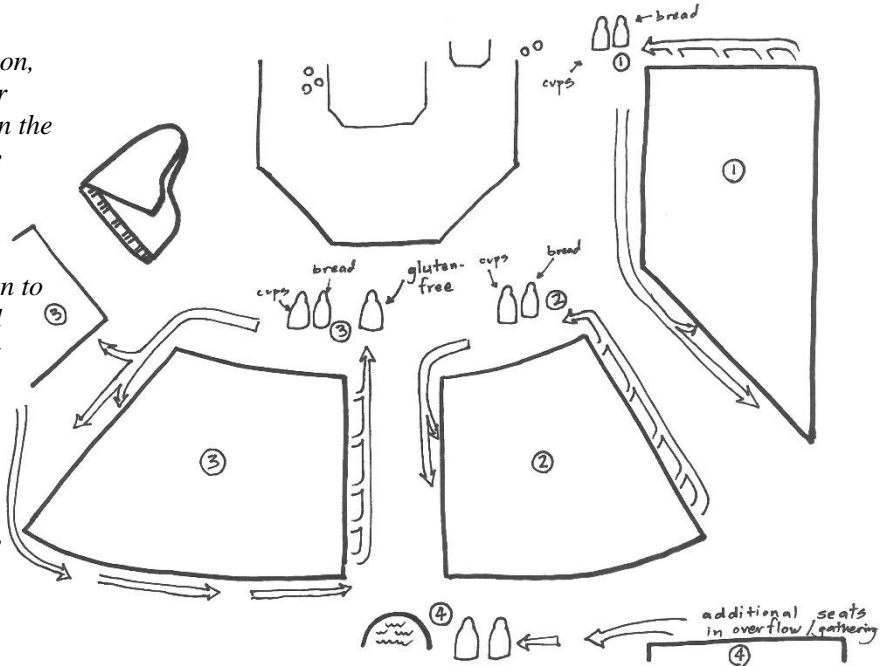

## Communion Hymns

### “Lamb of God”

*Congregation:*                      *Congregation or Assistant:*



Lamb of God,                      you take a - way the sin of                      the  
you break the chains of ha - tred                      and  
you are the way of jus - tice                      and  
you are the way of mer - cy                      and

*Congregation:*



world:                      have mer - cy on us,                      mer - cy on us,  
fear:  
peace:  
love.

**Final Stanza**

*Congregation or Assistant:*



mer - cy                      on                      us.                      Lamb of God,                      you

*Congregation:*



take a - way the sins of                      the world:                      grant us peace,



grant us peace,                      grant us                      peace.

Hymn

“All Are Welcome”

ELW 641

“The Church of Christ, In Every Age”

ELW 729

## Post Communion Blessing

### Prayer after Communion

AM Shepherding God, you have prepared a table before us and nourished us with your love. Send us forth from this banquet to proclaim your goodness and share the abundant mercy of Jesus, our redeemer and friend. **Amen.**

## THE SENDING

### **The Blessing**

**P** Alleluia! Christ is risen!

**Christ is risen indeed! Alleluia!**

The God of resurrection power, the Christ of unending joy, and the Spirit of Easter hope + bless you now and always. **Amen.**

### **Sending Hymn**

“O God Our Help in Ages Past”  
*High Voices Vs 3, Low Voices VS 4*

**ELW 632**

### **Dismissal**

**AM** Alleluia! Go in peace. Rejoice and be glad. **Thanks be to God. Alleluia!**

**AM** And next week, **C Bring a friend!**

### **Postlude**

**ABQ**

# Making Jesus Known”

Welcome to worship at Community of Christ as we mark a special milestone in our life together here! This Sunday marks the fiftieth anniversary of the first Sunday this congregation gathered for worship, and today we are grateful to have you with us as we worship the One in whose love we abide! With us today in worship are Bishop Daniel Beaudoin of our Northwestern Ohio Synod (ELCA) who is preaching today, as well as numerous pastors who have served this congregation in its history, whether as full-time called pastors, interim pastors, or those who have grown up in this congregation and been called to ministry elsewhere. We are thankful to you all for being with us to celebrate the abiding presence of the living God among us here at Community of Christ, and for sharing with us our common calling to *make Jesus known!* "Please join us in the gathering space after worship to share in refreshments and a time of fellowship!"

## **Adult Forum in April and May 2024: Scenes from a Movement**

Throughout the weeks of Eastertide, our first lessons in worship each Sunday will be stories from the Book of Acts, which chronicles the early church and the spread of the first followers of Jesus into the world. And yet, many of us are not very familiar with this part of the Bible or the meaning it holds for our lives today as the church. So, join us in the Adult Forum for the spring to take a closer look at these stories and the way the Christian community developed from a fearful band of former fishermen and tax collectors to a budding movement across the Roman Empire, and now to the whole world. Join us for “Scenes from a Movement: Stories from Acts” this April and May at 9:00 a.m. in the library for our Sunday morning Adult Forum class! Everybody is welcome!

Mark Your Calendars for **Saturday, June 8<sup>th</sup>**! Calling all walkers! Everyone LOVES a parade and our community is no exception. The Outreach Committee is organizing a group of spirited members to participate in the annual Whitehouse Cherry Fest parade this year on Saturday, June 8<sup>th</sup>. Line up begins around noon and the parade kicks off at 1 pm – candy for tossing to the crowd will be provided. Come help support our community and extend the celebration of Community of Christ’s 50 year anniversary. Sign up sheet is on the kiosk.

**Thank you to The Academy Brass Quintet and the Community of Christ Choir**  
for sharing your wonderful musical talent with us today!!!

**ABQ Musicians**

Dave Kosmyrna, trumpet  
Michael Smith, trumpet  
Hannah Opera, horn  
Bruce Heuring, trombone  
Jason Jordan, tuba

**Community of Christ Choir**

Pastor Steve Bond, Dick Burdo,  
Marsha Cochran,  
Elaine Hetherwick, Becky King,  
Wayne King, Marian Schlegal,  
Don Schroeder, Joan Schwartz,  
Dan Sigg, Molly Wachtmann  
Debbie Warner,  
Amanda Worthington



**More than an hour of beautiful music  
and lots of fond memories. Order your  
copy now! Envelopes are available in  
the Gathering Space.**

*Thank you*

We appreciate all who brought a dish to share for a Lenten Soup Supper, a special gathering, or a funeral luncheon. If you are missing your dish, we ask that you please check the kitchen! If dishes are not picked up by Wednesday, May 15, they will be donated to Goodwill.

Thank you, the Kitchen Team

**Altar Flowers are given by the Gebhart Family in Honor and Memory of Community of Christ Lutheran Church Senior Pastors during our 50 years! Pastor Ray Gottschling, Pastor Rich Ferne, Pastor Matt Lash, and Pastor Steve Bond.**

**Also, a special thank you to the pastors who have ministered to our congregation throughout the years!**



**“The LORD bless you  
and keep you;  
the LORD make his face shine on you  
and be gracious to you;  
the LORD turn his face toward you  
and give you peace.”**

<b>Visitation Ministry</b>
Monday, May 6
<b>Ladies Bible Study</b>
Tuesday, May 7
<b>LWR Quilt Ministry</b>
Tuesday, May 7
<b>Thursday Bible Study</b>
May 9, 1:00 p.m.

**Worship Services**  
Available on the net  
at  
[www.commofchrist.org](http://www.commofchrist.org)

**Join us on Facebook Live at  
10:00 a.m.**

**or  
in person!**

Worship & Sacrament  
Sunday 8 a.m. & 10:00 a.m.

**Sunday Morning Bible Study**  
9:00 a.m. – 9:45 a.m.

**AA Meeting**

Wednesdays 8 p.m.

**Midweek Bible Study**

Thursdays at 1:00 p.m.

**Caregivers Support Meeting**

First Monday of every month  
6:30 p.m.

**Clean & Feed Weekend**

4<sup>th</sup> Sunday of Every Month



Did one of our Bible readings capture your attention today? Was there a story you could picture in your mind? Did a phrase from a hymn or a thought from the sermon start some new ideas or inspire some reflection? Did a Scripture passage spark a question for you to think about? Use this space here as an open canvas for your faithful imagination: you can draw a picture of something you pictured, write a question,

take notes from the message or scriptures, or doodle your faith into a visible form here. Then, either take it with you or leave your thoughts and images here to be shared in an ongoing collection here at Community of Christ!